

Occupational Therapy Minor Home Modification

Occupational Therapist

Name:
Organisation:
Phone:
Email:
Days Available:

Client

Full Name:
Address:
Phone:
DOB:
Contact Person:

Date:

Toilet: Vertical Grabrail - Right hand side when seated

Location:

- main bathroom
- ensuite
- other (specify).....

Record dimensions in mm on diagram

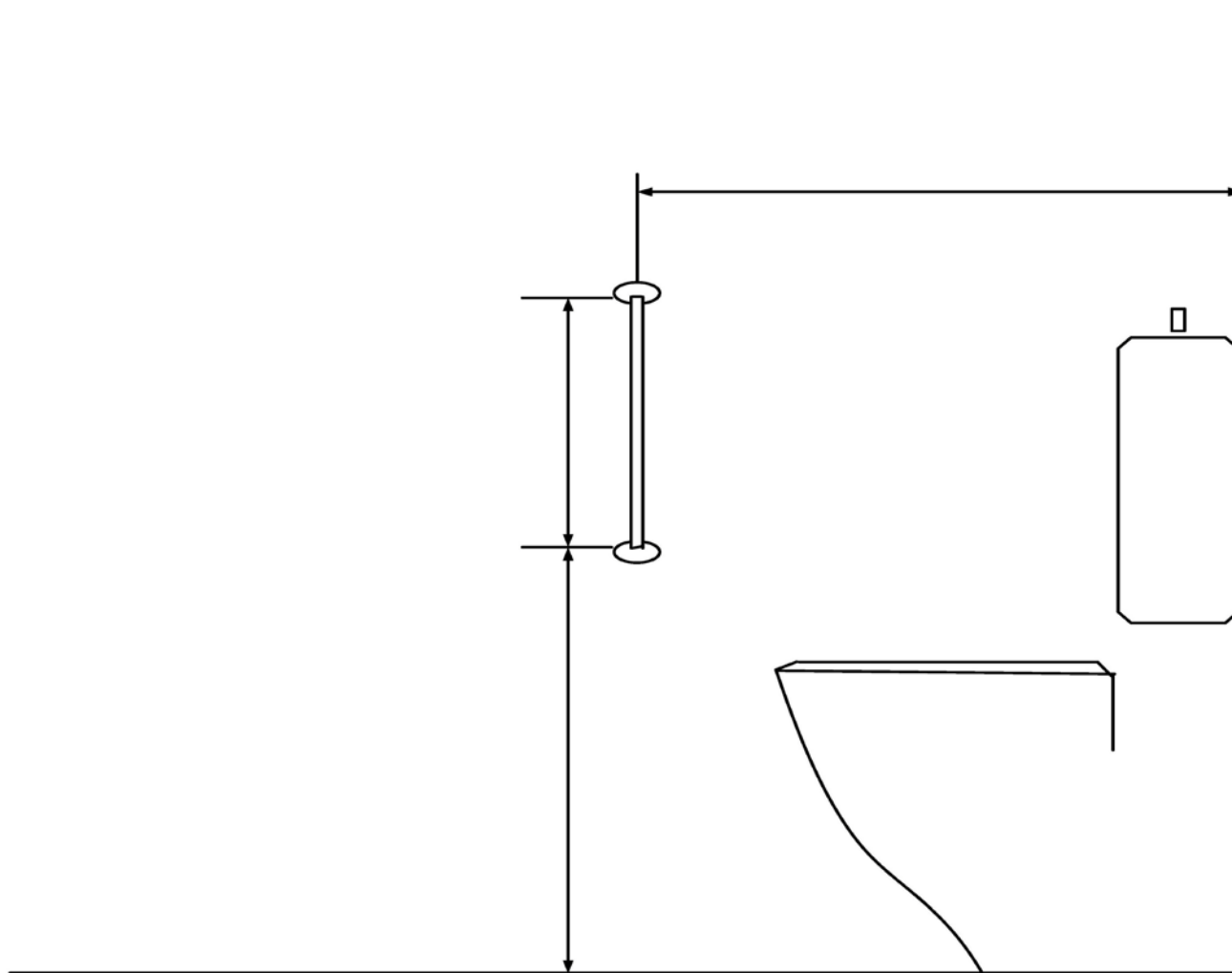



Occupational Therapist

Name:
Organisation:
Phone:
Email:
Days Available:

Client

Full Name:
Address:
Phone:
DOB:
Contact Person:

Date:

Toilet: Vertical Grabrail – Right hand side when seated

Location: main bathroom ensuite other (specify).....

Occupational Therapy Specifications

1. Install a vertical grabrail in main bathroom ensuite other (specify).....
.....
on wall on right hand side of toilet when seated
2. Minimum length of grabrailmm. Diameter of grabrailmm
3. Lowest fixing point to bemm above finished floor surface
4. Distance from back wall to bemm
5. Colour/finish (if required)
.....
.....
6. Wall type Stud Solid Uncertain
7. Weight of client (if over 100kg)kg
8. Other
.....
.....
.....
.....

OT Signature: _____

Date: _____

Not to scale All measurements in mm

Note: Grabrails must be secured to studs at both ends. If technical difficulties arise please contact the Occupational Therapist prior to or after completion of the work. If the client wishes to alter the specifications please contact the Occupational Therapist prior to work commencing.

Disclaimer: The recommendations contained in this form are made after consultation with the client and an investigation of the client’s circumstances and needs. Their purpose is to outline steps required to be taken for the benefit of the client, having regard for his or her disabilities. They do not purport to reflect other than limited knowledge on the part of the Occupational Therapist of structural considerations and building codes. Any queries, concerns or alterations considered necessary for compliance with current building regulations must be discussed with the Occupational Therapist before quoting for the cost of the work and before the work proceeds. The Occupational Therapist accepts no responsibility for supervision of the work or for the quality of the workmanship.